

LED Street Light Housing MLT-SLH-KXS-II



Brief Introduction

This LED street light housing fixture MLT-SLH-KXS-II is the smallest size of SMD LED street light housing fixture from Moonlight LED street light K series. Modern design, precision die-casting molded and superior corrosion resistant coating finish housing with standard twist lock photocell mounting platform, make this LED street light housing can be used for variety of LED roadway lighting applications.

MOONLIGHT TECHNOLOGY LIMITED

Feature

- ✧ Durable aluminum alloy die-casting LED street light housing for heavy-duty outdoor lighting applications.
- ✧ Ribbon-free and compact design.
- ✧ Separate LED light engine and driver box for easy maintenance.
- ✧ Tool-less design for replace the LED driver without any tool.
- ✧ The bottom of the driver box has the GND bosses for security.
- ✧ Plastic electrostatic spraying to resist corrosion, chipping and fading.
- ✧ Adjustable knuckle slip fitter with SUS304 stainless steel hardware secures fixture to pole arm.
- ✧ Side-entry or post-top mounting. Universal mounting pieces allows precise adjustment on-site.
- ✧ 5mm high light transmittance tempered glass diffuser.
- ✧ Silicon gaskets.
- ✧ SUS304 stainless steel bolts and clips for fastening
- ✧ Standard S6000 socket and twist lock photocell mounting platform for lighting control.
- ✧ Quick disconnection terminal block mounting platform for disconnect the power supply for linemen handling security.
- ✧ IP66 rated, protect from all dust and harsh weather.
- ✧ Standard Gray finish.
- ✧ Easy to assemble, install and linemen friendly maintain.

MOONLIGHT TECHNOLOGY LIMITED

Mechanical Dimensions

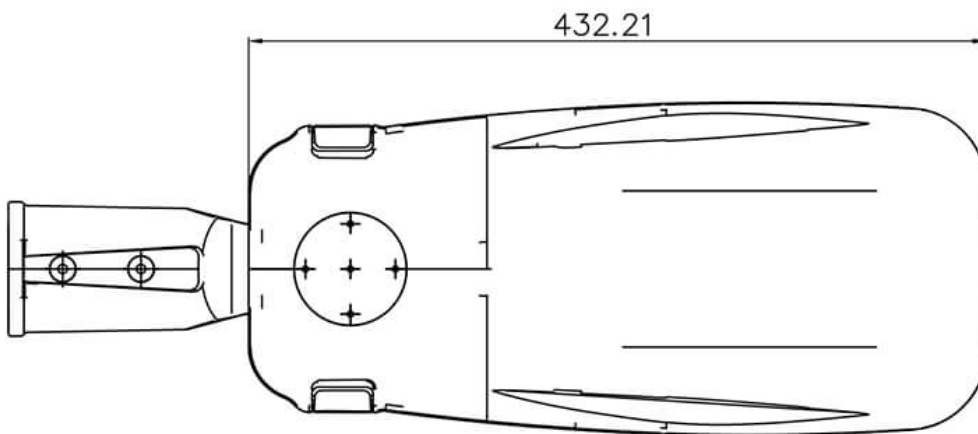
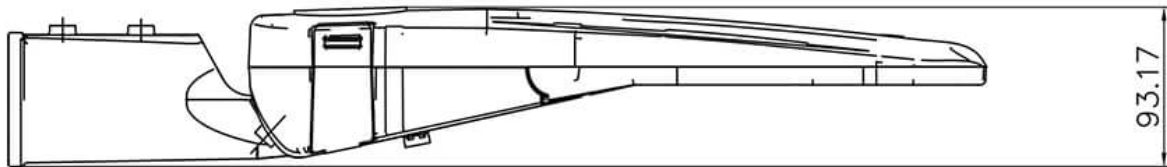
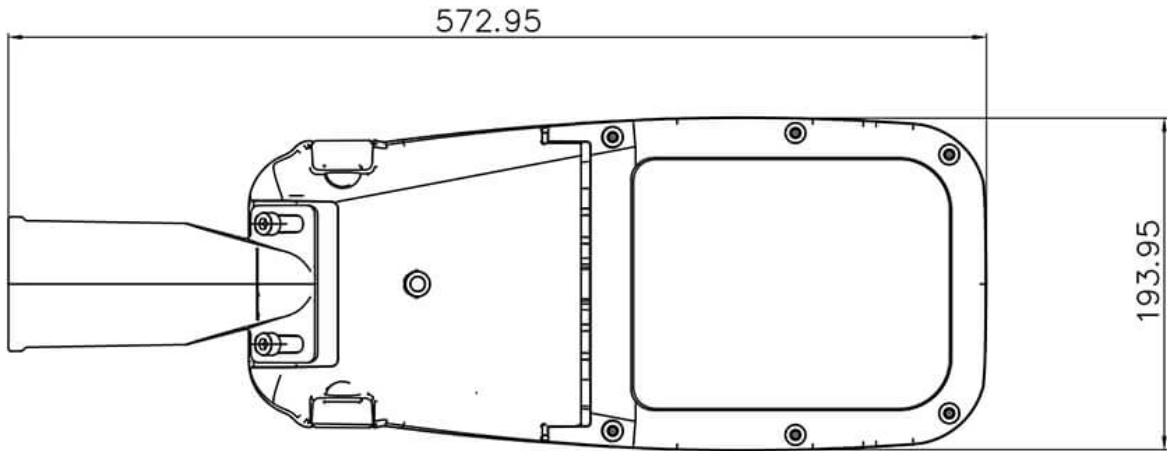

MOONLIGHT TECHNOLOGY LIMITED

Parameter

| | |
|------------------------------------|---|
| Model No. | LED Street Light Housing MLT-SLH-KXS-II |
| Dimension of Housing | 57.2cm(L)*19.5cm(W)*9.3cm(H) |
| Fixture Material | Die-casting Aluminum Alloy |
| Die-casting Aluminum Alloy Weight | 2200g |
| Surface Finish Color | Gray or Customized color |
| Material of Diffuser | High Transmittance Tempered glass |
| Effective MCPCB Mounting Size | 175mm(L)*130mm(W) |
| Compatible Lenses | 6PCS 50mm*50mm Lenses |
| Recommended LED Power | 40W to 80W |
| Driver Box Dimension | 150mm(L)*85mm(W)*50mm(H) |
| Pole Mounting | Accommodates up to Φ 65mm pipe |
| Adjustable Slip Fitter | -15° to +15° |
| Standard Photocell | Optional |
| Quick Disconnection Terminal Block | Optional |
| IP Rating | IP66 |

Pictures

Front View



Back View



Packing Information

| | |
|--------------|---------------------------|
| Net Weight | 3.0kg/PCS |
| Gross weight | 3.5kg/carton |
| Quantity | 1PCS/ carton |
| Carton Size | 61cm(L)*23cm(W)*13.5cm(H) |

Application

This heavy-duty, modern design and cost-effective LED street light housing fixture is typically used as 40W-80W LED street lighting fixture. LED street lighting is used extensively in urban settings, along small town downtown main streets, in residential neighborhoods, in commercial districts, public squares, in industrial parks, at interstate highway interchanges, bridges, and rural intersections.